

# Ikegami



4K/HD CAMERA SYSTEM

**UNICAM XE**

Reach for Reality



Xceptional Engineering  
Xcellence Enabler  
Xtended Evolution

# UNICAM XE

HDK-X500

With newly incorporated features and uncompromising image quality, the UNICAM XE family covers all aspects of advanced broadcasting production from standard 4K/HD footage to high frame rates and XR applications effectively and efficiently.

Choose your UNICAM XE and experience a more versatile and streamlined production workflow.





LINEUP

## UHK-X700

4K/HD Portable Camera System

**4K**  
**HFR**  
**MoIP**

<b>4K</b> 2160p	<b>HD</b> 1080p/i	<b>HD</b> 720p	F10/59.94p F11/50p
<b>HDR</b>	<b>ADV</b> <b>HFR</b>	<b>EXT</b> <b>HFR</b>	

## UHK-X750

4K/HD Studio Camera System

## UHK-X600

4K upgradeable  
HD Portable Camera System

**4K**  
**HFR**  
**MoIP**

<b>HD</b> 1080p/i	<b>HD</b> 720p	F10/59.94p F11/50p	<b>HDR</b>
<b>4K</b> 2160p	<b>ADV</b> <b>HFR</b>		

## UHK-X650

4K upgradeable  
HD Studio Camera System

## HDK-X500

HD Portable Camera System

**HD**  
High Definition  
**MoIP**

<b>HD</b> 1080p/i	<b>HD</b> 720p	F11/59.94p F12/50p	<b>HDR</b>
<b>4K</b> <b>Upscaling</b>			

Option

UHK-X750

# Features

## UNICAM XE

### Natural Image Expression

The 3-CMOS optical system uses a 2/3-inch CMOS sensor and boasts an S/N of 62dB plus a sensitivity of F11 (2160/50p)/F10 (2160/59.94p) in 4K (UHK-X700). The high dynamic range of the sensor produces high-quality images with excellent color reproduction. The CMOS sensor incorporates a global shutter pixel architecture, enabling the camera to capture natural images even in challenging situations. Still frame replay of fast-moving objects is free from geometric distortion. And there are no flash bands when the camera is shooting under strobe lights or flashes from still cameras.

#### Rolling Shutter CMOS

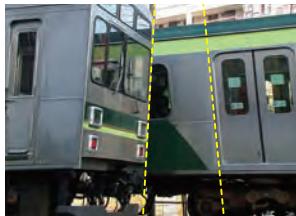

Geometric Distortion

#### Global Shutter CMOS

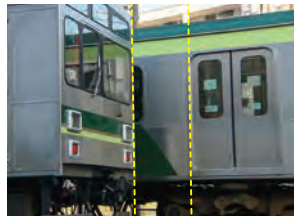

No Rolling Shutter Artifacts with Global Shutter



Flash-Band



### High Frame Rate Capturing (Option)

The UHK-X700/X600 supports high frame capturing options (with BSX-100). With the EXT-HFR option, up to 2x speed in 4K and up to 8x speed in HD are supported.



	UHK-X700/X750	UHK-X600/X650
Advanced HFR x 2,3,4 in HD	Yes	Yes
Extended HFR x 2,3,4,6,8 in HD/x2 in 4K	Yes	No

### Self-contained operation

The integrated video processor also enables self-contained operation in 4K. UNICAM XE can utilize a wide range of video devices as accessories to enhance its operational capabilities.



Example of System: Camera Head



\* D-TAP is available only for UHK-X700 & X600.

### HDR and Wide Color Gamut

HDR is supported by the HLG (Hybrid Log Gamma) system as standard. Wide color gamut shooting conforms to ITU-R BT.2020, enabling natural and rich color expression. The camera is equipped with customizable preset gamma curves and preset matrices for BT.2020 and BT.709 color reproduction, enabling optimal adjustment of the camera image to match the requirement of the current production.



Standard Dynamic Range



High Dynamic Range

Images are for illustration

# Exclusive Features of the UHK-X700 and X600

## 3840 x 2160 4K Capturing

The UHK-X700/X750 supports 3840 x 2160 effective resolution as standard. Applying an optional license key unlocks the UHK-X600/X650 for capturing the same 3840 x 2160 effective resolution images.

## 4K/HD Simulcast (Option for UHK-X600/X650)

The live image captured in 4K HDR can be delivered simultaneously in HD SDR from the base station. The image processing in the BSX-100 gives the optimum look for the converted images.

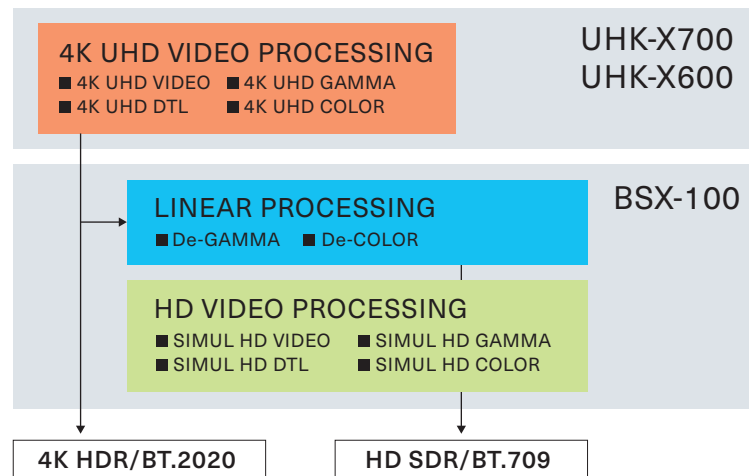

## 4K 12G-SDI Video Trunk (Option)

Utilizing a wide transmission bandwidth, the bi-directional 12G-SDI trunk line is available between the UHK-X700 and the BSX-100. Besides a main 4K image, the 4K Video Trunk (UHK-X700 to BSX-100, asynchronous signal) and the 4K QTV (BSX-100 to UHK-X700) can be transmitted at the same time on a Hybrid Fiber Optic cable.

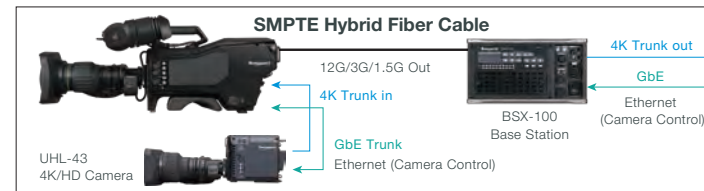

## GbE Ethernet Trunk

An Ethernet data trunk line between the camera head and the BS supports the vast capacity of 1G bps. Data rate is constant and not affected by the video format to operate. Jumbo frame is to be supported.

## Optimal Camerawork with Box Lenses

The UHK-X750/X650 allows optimal camerawork for live production with a large lens. Thanks to its low-profile body, the viewfinder can be positioned close to the height of the optical axis.



— VF Position(SE)  
— VF Position(UHK-X750)  
— Optical Axis

## Common features

### 16-axis Color Corrector

This function independently adjusts the hue and saturation of specific colors. It permits subjective manipulation of one color without affecting the other colors in the scene.



Original

Corrected

### Optical Vignetting Correction (OVC)\*

Automatic electronic compensation of F-drop and vignetting.

\* with supported lenses



### Remote Back Focus Adjustment (RBF)\*

The OCP-300 & 500 can remotely adjust the back focus of a zoom lens. The adjustment is accurate and easy with a large display for the video engineer, even when the camera head is located in an environment where it is hard to clearly see the VF or reach the back focus on the lens.

\* with supported lenses

### Focus Assist

Contour extracted from the 4K image is displayed in the viewfinder to assist precise focusing. The size and color of the focusing area, and the color of the indicator, can be optimized by menu settings.



### Lens Chromatic Aberration Correction (CAC)

With compatible lenses, the color fringing in peripheral images can be minimized.

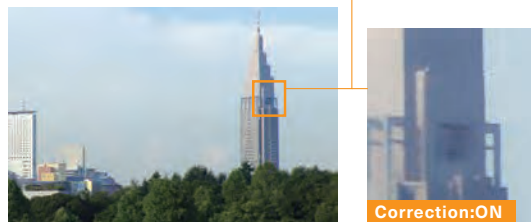

### Ergonomic Design

As the UHK-X700 is a portable camera, the weight distribution ratio has been totally refined from its predecessor model.

A lower center of gravity and a well-balanced body help to reduce operator fatigue.



Wide adjustable range of shoulder pad



Shoulder pad is placed 30mm forward of the previous model

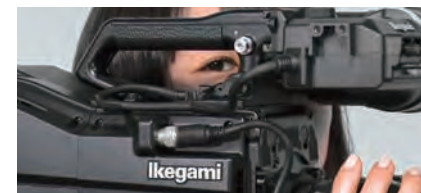

Improved field-of-view over the camera

Images for illustration

# BSX-100

## 4K/HD Base Station

The BSX-100 is a base station that enhances the functions, performance, and operational capabilities of the UNICAM XE. It is compact and light weight, with 3U height and half-rack width. Supporting both 4K and HD formats, it is ideal for simulcast production and smooth transition from HD to 4K environments.



Front



Rear

## Compatible with 4K & HD Cameras (Option)

The BSX-100 supports either HD cameras, 4K cameras, or both camera types. The following models are available:  
BSX-100 U: for UNICAM XE (UHK-X700/X750/X600/X650) cameras  
BSX-100 M: for UNICAM XE and Unicam HD (HDK-73/99) cameras  
BSX-100 H: for UNICAM XE (HDK-X500) and Unicam HD cameras

## 4K & HD Simulcast\*

The BSX-100 U and M have a total of 11 outputs as standard, including 4K output via 12G-SDI and 3G-SDI/HD-SDI.

\* with supported cameras

## Maximum Transmission Distance\*

The BSX-100 extends the UNICAM XE camera up to 3.5 km (11,483 ft.) with a Hybrid Fiber Optic cable. In the Single Fiber mode, the cable length reaches up to 10 km (32,808 ft.).

\* Depends on operating conditions.

## Compact and Light Weight

3U height and half-rack width.



## Front Information Display

LED indicators can monitor the communication status between the camera head and the BS as well as the operational status. In the 7-segment LED display, the status of the device can be checked without entering the OSD menu, including system format, IP address (divided into octets), software version, and error information.

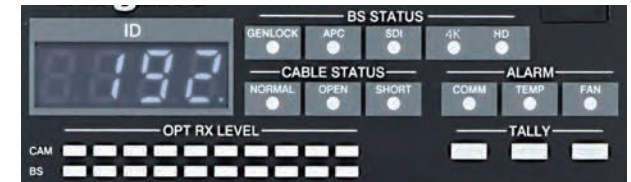

# CCU-X100

## Camera Control Unit

Employing the upscaled power supply unit, the CCU-X100 can extend the UNICAM XE cameras even over the greater distance.



## MoIP Interface

All UNICAM XE series products are designed to support the interoperability with the ST2110 media-over-IP network by incorporating an optional MoIP Module at the BSX-100/CCU-X100. Perfect for live sports, news broadcasts, and remote production environments, the BSX-100 MoIP bridges the baseband and the IP-based media workflows.

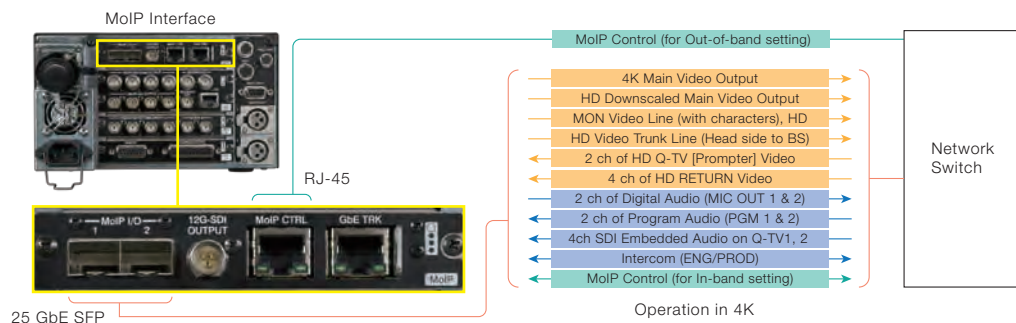

## Support of NMOS

The AMWA NMOS (IS-04 & IS-05), which is widely adopted as a control method for IP networks, is supported, enabling device registration and interconnection within an IP network from broadcast controllers.

## HFR, HDR, and UHD over IP streams

Not only the conventional 4K/HD program video output, HFR and HDR images can be output as IP streams with simultaneous output of the standard frame rate video for HFR capturing and HD SDR video for 4K HDR capturing.

## Network Tally

The BSX-100 supports TSL V5.0 IP network tally protocol as standard.

## IPX-100 IP Extension Unit



The IPX-100 is an external IP gateway for the UNICAM XE and Unicam HD cameras. By converting baseband signals to and from IP streams, the IPX-100 integrates the Unicam cameras directly to an ST2110 media-over-IP network.

### Maximum Cable Extension

Using the trusted SMPTE hybrid fiber optic cable, the IPX-100 provides a stable connection and supplies remote power to the connected camera head up to 3500m.

### Form factor

The compact 2U half-rack enclosure enables high-density mounting in an EIA rack. It is also easy to transport, making it ideal for field use. It is highly effective for a wide range of live video production applications.

### JPEG XS (option)

The IPX-100 optionally supports JPEG XS (SMPTE ST2110-22 compliant) encoding and decoding. The IPX-100 provides the selectable data rate in four steps: High (1/5), Mid (1/8), Low (1/16), and Mini (1/32), allowing users to choose an optimal setting according to operational conditions.

### IP Gateway function (option)

An optional IP Gateway function utilizes one of the conversion channels for external input and/or output, allowing SDI devices to seamlessly connect to the ST2110 media-over-IP network without needing an external IP conversion box.

### Ideal for IP Remote Production

The IPX-100 directly attaches UNICAM XE cameras to a media-over-IP network while maintaining the most trusted and widely used workflow with SMPTE fiber cables. With the aid of optional JPEG XS, the IPX-100 provides the most efficient workflow for IP remote production. Experience a more reliable and streamlined IP remote production workflow with the IPX-100.

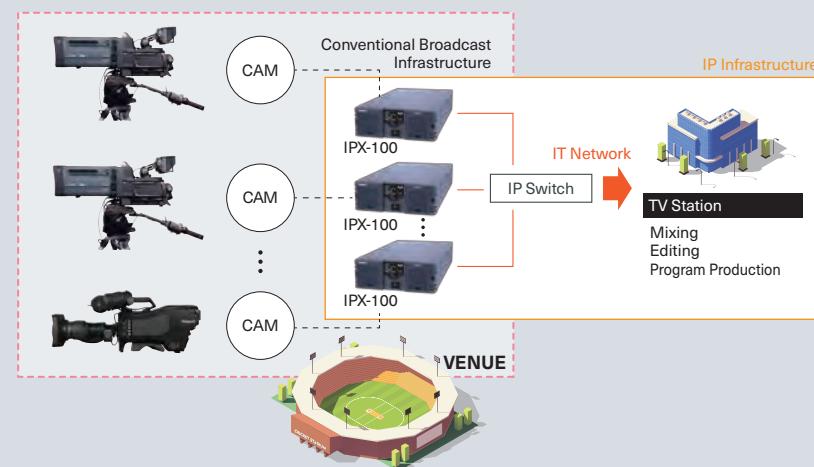



## Accessories



2-inch LCD Ocular Viewfinder  
**VFL201D**



7-inch Full-HD LCD Viewfinder  
**VFL-P700AD**



System Expander  
**SE-U430**



Tripod Adaptor  
**T-430**



Shotgun Microphone  
**SGM-3500**  
A product of Azden Corp.

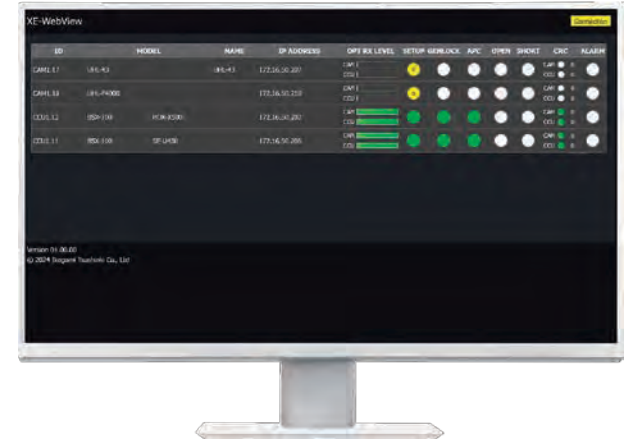

User interface on Web browser  
**XE WebView**

XE WebView is a newly introduced web tool. With the aid of Ikegami Protocol Gateway, the web UI provides diagnostic information on the camera chains individually or in the overview. XE WebView enhances the flexibility and scalability of the camera systems, especially in the MoIP environment where device management is crucial.



New Operation Control Panel  
**OCP-500**

With a slim panel surface measuring just 82mm (3.23 inches) wide, the newly developed OCP-500 offers space-saving efficiency without compromising functionality. Up to five OCP-500 units fit into the same desktop footprint as four OCP-300.

### Features

- 2.8 inch LCD touch screen
- Self illuminated buttons
- Low power consumption
- USB for external storage



Master Control Panel  
**MCP-300**



Operation Control Panel  
**OCP-300**



Virtual Control Panel  
**VCP**



Virtual Master-control Panel  
**VMP**

# Specifications

Camera Head	UHK-X700 UHK-X750		UHK-X600 UHK-X650		HDK-X500	
Image Sensor	2/3-inch CMOS Sensor with Global Shutter Architecture		2/3-inch CMOS Sensor with Global Shutter Architecture		2/3-inch CMOS Sensor with Global Shutter Architecture	
Optical System			2/3-inch 3-sensor, RGB Prism			
Effective Resolution	3840 x 2160 59.94p, 50p	Yes	Optional		No	
	3840 x 2160 23.98p, 29.97p, 25p	Optional	Optional		No	
	1920 x 1080 59.94p, 50p, 59.94i, 50i	Yes	Yes		Yes	
	1920 x 1080 23.98p/SF, 29.97p/SF, 25p/SF	Optional	Optional		Optional	
	1280 x 720 59.94p, 50p	Yes	Yes		Yes	
1080p --> 2160p upscaling	No	No		with optional upscaler for BS		
Optical Filters (Servo Controlled)	Position	1	2	3	4	5
	ND	CLR	1/4	1/8	1/16	1/64
	CC	3200 K	4300 K	6300 K	Cross	Option
S/N Ratio	4K	62 dB or better		62 dB or better (optional)		—
	HD	62 dB or better		62 dB or better		62 dB or better
Limiting Resolution	4K	2000 TVL or more		2000 TVL or more (optional)		—
	HD	1000 TVL or more		1000 TVL or more		1000 TVL or more
Sensitivity (2000 lux, 89.9% Reflection)	F10/59.94p, F11/50p		F10/59.94p, F11/50p		F11/59.94p, F12/50p	
Gain-up	-6, -3, 0, +3, +6, +9, +12 dB				-6, -3, 0, +3, +6, +9, +12, +18 dB	
Gamma Curves	OFF, 0.35, 0.4, 0.45, HLG, Custom 1 - 5					
Electronic Shutter	1/100, 1/120, 1/250, 1/500, 1/1000, 1/2000, and Variable Shutter					

Video I/O (Rear Panel)	Designation				
Video Out	SDI OUT 1-3	3 x BNC, 12G/3G/HD-SDI		SDI OUT 1-2	
Video In/Out	SDI I/O 4	1 x BNC, 12G/3G/HD-SDI		SDI I/O 3	
Reference Video In/Out	GL IN/ SYNC OUT	1 x BNC	Input: Tri-Sync or BB Output: BB		
I/O (Top Handle)	Designation				
Video Out	SDI OUT	1 x BNC, 3G/HD-SDI		SDI OUT	
				1 x BNC, 3G/HD-SDI (optional)	

Other I/O	Designation			
SMPTE Hybrid Fiber Camera Cable	LEMO 3K Type (SMPTE 304M)			
Microphone	MIC 1/2	XLR-3, input level: -60 to +4 dBu/Phantom Power: Off/+12 V/+48 V		
Intercom	Intercom 1/2	XLR Type		
Phones	EARPHONE	1 x 3.5 mm Stereo mini jack	1 x 3.5 mm 4-pol mini jack (CTIA)	
Audio Out	PGM	XLR-3 (optional)		
Tracker	TRACKER	20-pin		
USB 2.0	USB	1 x Type-A, for USB flash drive		
Ethernet	LAN	1 x RJ-45, connection for OCP-300/500 (via PoE+ switch) or GbE Data Trunk		—
System Expander	—	for SE-U430		
DC Power Output		D-TAP: max. 2.5 A 12 V/DC OUT: max. 1.0 A 12 V		DC OUT: max. 1.0A 12 V

General Specifications				
Ext. Power Input Voltage	UHK-X700/X600	+11 to 17 V DC		+11 to 17 V DC
	UHK-X750/X650	100 to 240 V AC		
Ambient Temperature	Operation: -20 °C to +45 °C (-4 °F to +113 °F)/Storage: -30 °C to +60 °C (-22 °F to +140 °F)			
Operation Humidity	30 % to 90 % *non-condensation			
Dimensions (Excluding protrusion)	UHK-X700/X600	W 148.5 x H 243 x D 340 mm/W 5.9 x H 9.6 x D 13.4 inches		W 148.5 x H 243 x D 340 mm/W 5.9 x H 9.6 x D 13.4 inches
	UHK-X750/X650	W 315 x H 375.5 x D 398 mm/W 12.4 x H 12.9 x D 15.7 inches		
Weight (Camera Head)	UHK-X700/X600	Approx. 5 kg/11 lb		Approx. 4.7 kg/10 lb
	UHK-X750/X650	Approx. 18 kg/39.7 lb		
Power Consumption	UHK-X700/X600	85 W		56 W
Max. in self-contained operation	UHK-X750/X650	120 W		

BSX-100/CCU-X100 Type U and M

Supported Camera Models	
UHK-X700/X750, UHK-X600/X650	Type U and M
HDK-X500	Type M
HDK-99, HDK-73	Type U

Video I/O	Designation		
Video In	RET	4 x BNC	4-input or 2-in/2-out (Active Loop-through)
	HD QTV	2 x BNC	2-input or 1-in/1-out (Active Loop-through)
	4K QTV	1 x BNC	12G-SDI, shared with 12G OUT 3-4 * (option)
Video Out	OUT 1-4	4 x BNC	4K 3G-Quad Link (2SI) or 3G/HD
	OUT 5-8	4 x BNC	3G/HD, OUT 8 is for HD-SDI MON out
	12G OUT 1-4	4 x BNC	4K 12G-SDI or 3G-Quad Link (2SI)
	HD TRUNK	1 x BNC	HD-SDI, shared with OUT 5-7 *
	4K TRUNK	1 x BNC	12G-SDI, shared with 12G OUT 3-4 * (option)
Genlock	REFERENCE	2 x BNC	Tri-Sync or BB, Active Loop-through
	SYNC/AES	1 x BNC	Tri-Sync out or Digital Audio out (AES/EBU)

\* Configurable by menu setting

Optional MoIP I/O	Designation		
IP Media Stream	MoIP I/O	2 x SFP	10G/25G
			SMPTE ST2110 Compliant
Video Out	12G-SDI OUTPUT	1 x BNC	4K 12G-SDI or 3G/HD-SDI
NMOS Control	MoIP CTRL	1 x RJ-45	JT-NM TR1001

Other I/O	Designation		
SMPTE Hybrid Fiber Camera Cable	—	LEMO 3K Type (SMPTE 304M)	
System I/F	COMMUNICATION	D-Sub 25-pin	Intercom, PGM Audio & Tally In
Mic Gain Remote	REMOTE	D-Sub 15-pin	Enable/Fine Gain/Step Gain
Data Trunk CH-1	DATA TRK-1	D-Sub 9-pin	RS-422
Data Trunk CH-2	IF	12-pin	RS-422, Preview, etc.
Data Trunk (Ethernet)	GbE TRK	1 x RJ-45	Max. 1000BASE-T (for UHK-X700/X600)
Tally Out	TALLY OUT	5-pin	
Audio Out	AUDIO OUT-1/2	XLR-3	Analog Microphone Output
Command Control	OCP	8-pin	CP Connector
	LAN	RJ-45	ICCP over Ethernet, TSL Tally (V5.0)

BSX-100/CCU-X100 General Specifications		
Input Voltage	BSX-100 & CCU-X100	100 to 240 V AC ±10%
Power Consumption	BSX-100	max. 100 VA (Type U)
	CCU-X100	max. 120 VA (Type M)
Ambient Temperature	BSX-100 & CCU-X100	Operation: 0 °C to +40 °C (32 °F to +104 °F)
		Storage: -30 °C to +60 °C (-22 °F to +140 °F)
Operation Humidity	BSX-100 & CCU-X100	30 % to 90 % *non-condensation
Dimensions (Excluding protrusion)	BSX-100	W 216 x H 123.6 x D 417.2 mm/W 8.5 x H 4.9 x D 16.0 inches
	CCU-X100	W 482.6 x H 132.6 x D 398 mm
Weight	BSX-100	Approx. 7 kg/15.5 lb
	CCU-X100	Approx. 17 kg/37.5 lb

BSX-100/CCU-X100 Type H

Supported Camera Models	
HDK-X500	
HDK-99, HDK-73	

Video I/O	Designation		
Video In	RET	4 x BNC	4-input or 2-in/2-out (Active Loop-through)
	HD QTV	2 x BNC	2-input or 1-in/1-out (Active Loop-through)
Video Out	OUT 1-4	4 x BNC	3G/HD, 4K 3G-Quad Link (upscaling from 1080p) as option
	OUT 5-8	4 x BNC	3G/HD, OUT 8 is for HD-SDI MON out
	12G OUT 1-4	4 x BNC	12G-SDI or 3G-Quad Link (option)
	HD TRUNK	1 x BNC	HD-SDI, shared with OUT 5-7 *
Genlock	REFERENCE	2 x BNC	Tri-Sync or BB, Active Loop-through
	SYNC/AES	1 x BNC	Tri-Sync out or Digital Audio out (AES/EBU)

\* Configurable by menu setting

Optional MoIP I/O	Designation		
IP Media Stream	MoIP I/O	2 x SFP	10G
			SMPTE ST2110 Compliant
Video Out	12G-SDI OUTPUT	1 x BNC	3G/HD-SDI
NMOS Control	MoIP CTRL	1 x RJ-45	JT-NM TR1001

Other I/O	Designation		
SMPTE Hybrid Fiber Camera Cable	—	LEMO 3K Type (SMPTE 304M)	
System I/F	COMMUNICATION	D-Sub 25-pin	Intercom, PGM Audio & Tally In
Mic Gain Remote	REMOTE	D-Sub 15-pin	Enable/Fine Gain/Step Gain
Data Trunk CH-1	DATA TRK-1	D-Sub 9-pin	RS-422
Data Trunk CH-2	IF	12-pin	RS-422, Preview, etc.
Tally Out	TALLY OUT	5-pin	
Audio Out	AUDIO OUT-1/2	XLR-3	Analog Microphone Output
Command Control	OCP	8-pin	CP Connector
	LAN	RJ-4	ICCP over Ethernet, TSL Tally (V5.0)

IPX-100

Supported Camera Models	
UHK-X700/X750, UHK-X600/X650	Type U and M
HDK-X500	Type H and M
HDK-99, HDK-73	Type H and M

Optional MoIP I/O	Designation		
IP Media Stream	MoIP I/O	2 x SFP	10G/25G
			SMPTE ST2110 Compliant
NMOS	NMOS	1 x RJ-45	JT-NM TR1001
Command Control	CAM CTRL	1 x RJ-45	ICCP over Ethernet, TSL Tally (V5.0)
Data Trunk (Ethernet)	GbE TRK	1 x RJ-45	max. 1000BASE-T (for UHK-X700/X600)

Video I/O	Designation		
Video In	SDI to IP	1 x BNC	for optional IP Gateway function
	MON	1 x BNC	HD-SDI MON out
Video Out	IP to SDI	1 x BNC	for optional IP Gateway function

Other I/O	Designation		
SMPTE Hybrid Fiber Camera Cable	LEMO 3K Type (SMPTE 304M)		

General Specifications	
Input Voltage	100 to 240V AC ±10%
Power Consumption	max. 130W (Type U)
Ambient Temperature	Operation: 0 °C to +40 °C (32 °F to +104 °F)
	Storage: -30 °C to +60 °C (-22 °F to +140 °F)
Operation Humidity	30 % to 90 % *non-condensation
Dimensions (Excluding protrusion)	W 216 x H 79 x D 407.2 mm
Weight	Approx. 5 kg/11 lb

# System Diagram

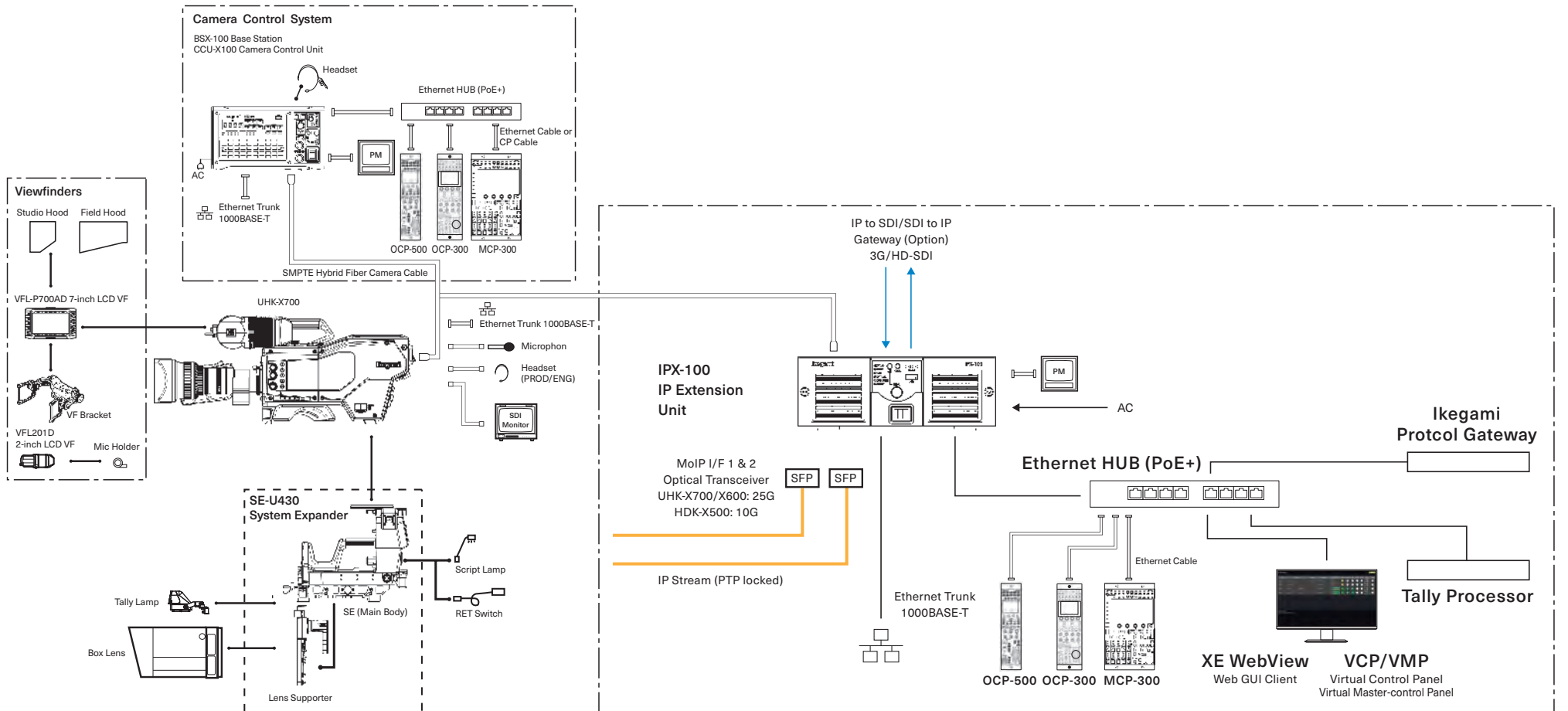

Ethernet Trunk is supported by Type U and M

Design and specifications are subject to change without notice



U552A2412-1B

## Ikegami Tsushinki Co., Ltd.

■ URL : [www.ikegami.co.jp/en/](http://www.ikegami.co.jp/en/)

■ **Head Office** : 5-6-16 Ikegami, Ohta-ku, Tokyo 146-8567, Japan ..... TEL.+81-(0)3-5700-1111 / FAX.+81-(0)3-5700-1137  
 ■ **Beijing Office** : Tower A Room No.823-824 Jia Tai International Mansion No.41 East Fourth Ring Road, Chaoyang District, Beijing, China ..... TEL / FAX.+86-10-8571-0350

## Ikegami Electronics (U.S.A.), INC.

■ URL : [www.ikegami.com](http://www.ikegami.com)

■ **Headquarters** : 300 Route 17 South, Mahwah, NJ 07430, U.S.A. .... TEL.+1-201-368-9171 / FAX.+1-201-569-1626

## Ikegami Electronics (Europe) GmbH

■ URL : [www.ikegami.de](http://www.ikegami.de)

■ **Headquarters** : Ikegami Strasse 1, D-41460 Neuss, Germany ..... TEL.+49-(0)2131-1230 / FAX.+49-(0)2131-102820

## Ikegami Electronics Asia Pacific Pte. Ltd.

■ URL : [sg.ikegami.co.jp](http://sg.ikegami.co.jp)

■ **Headquarters** : 1 Tampines Central 5, #06-04 CPF Tampines Building, Singapore 529508 ..... TEL.+65-6260-8820 / FAX.+65-6260-8896

